

**ZIG ZAG PRESSER FOOT**  
For over edging, block satin stitch, general zig zag and straight stitch work.  
No. 530603-02  
For all models.

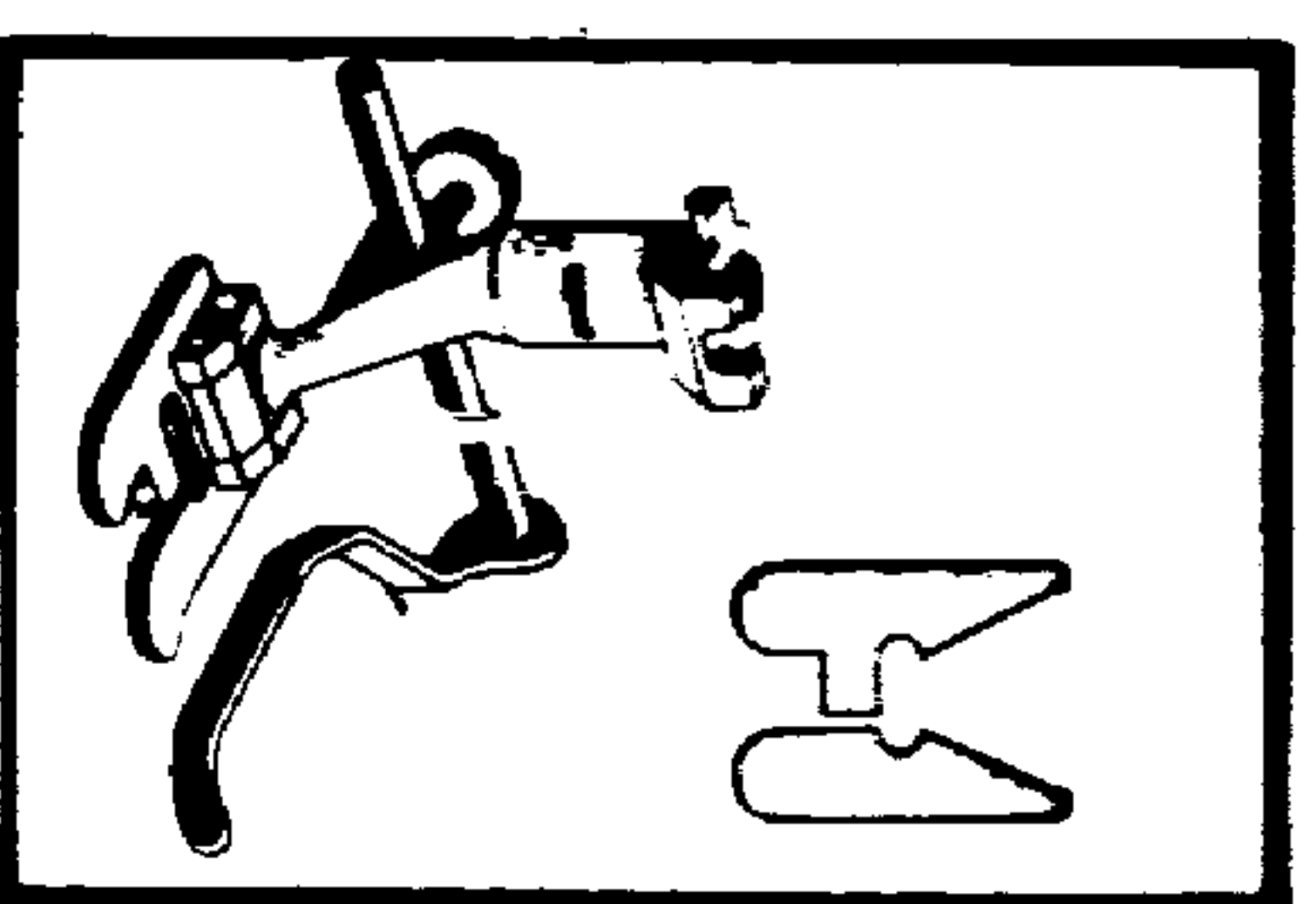

**ZIG ZAG EMBROIDERY FOOT WITH GUIDE**  
For embroidery patterns on automatic models.  
No. 530685  
For Swing Needle and Automatic Models only.

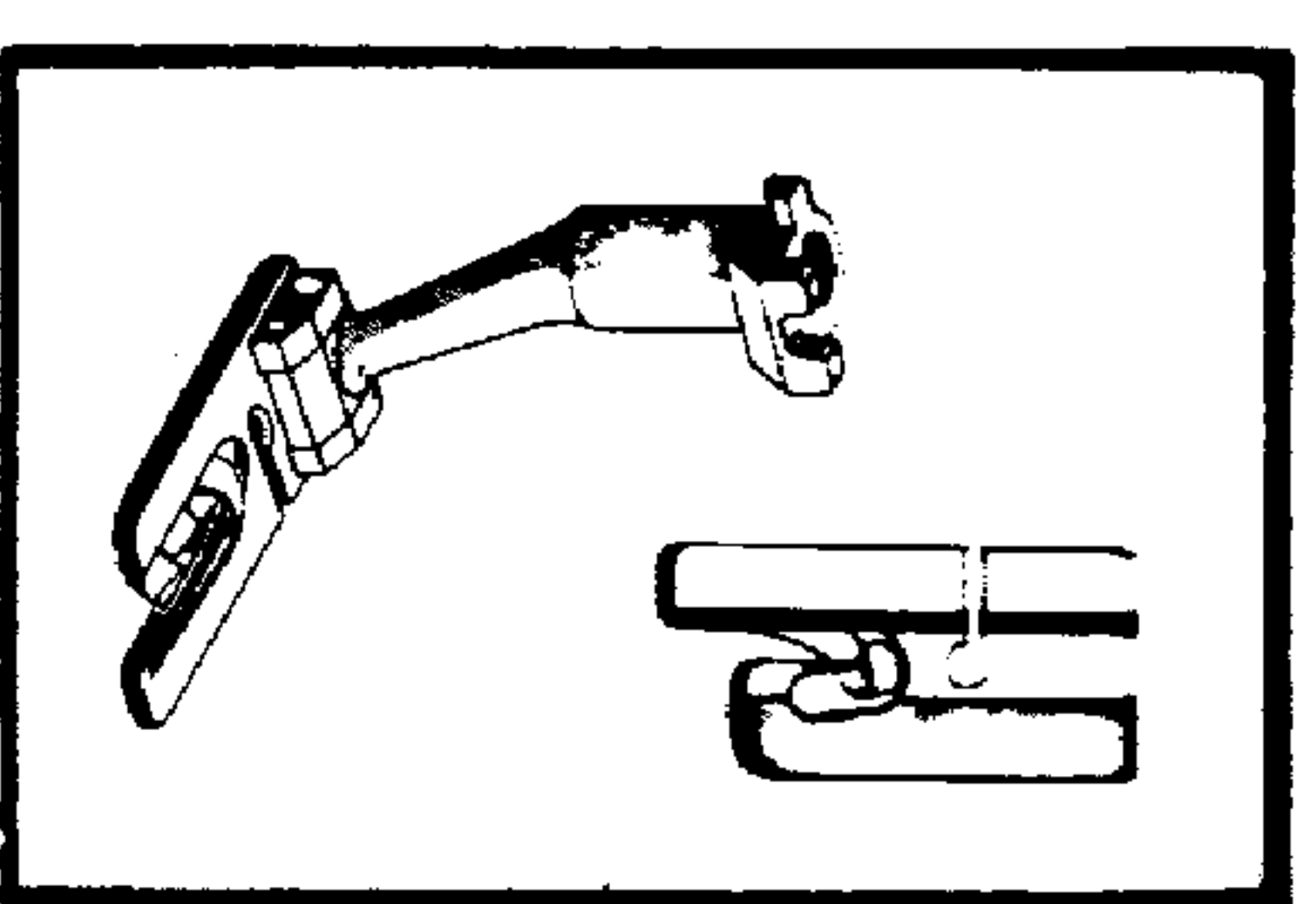

**WIDE HEMMER FOOT**  
For making  $\frac{3}{4}$ " hems.  
No. 530608  
For Swing Needle and Automatic Models.

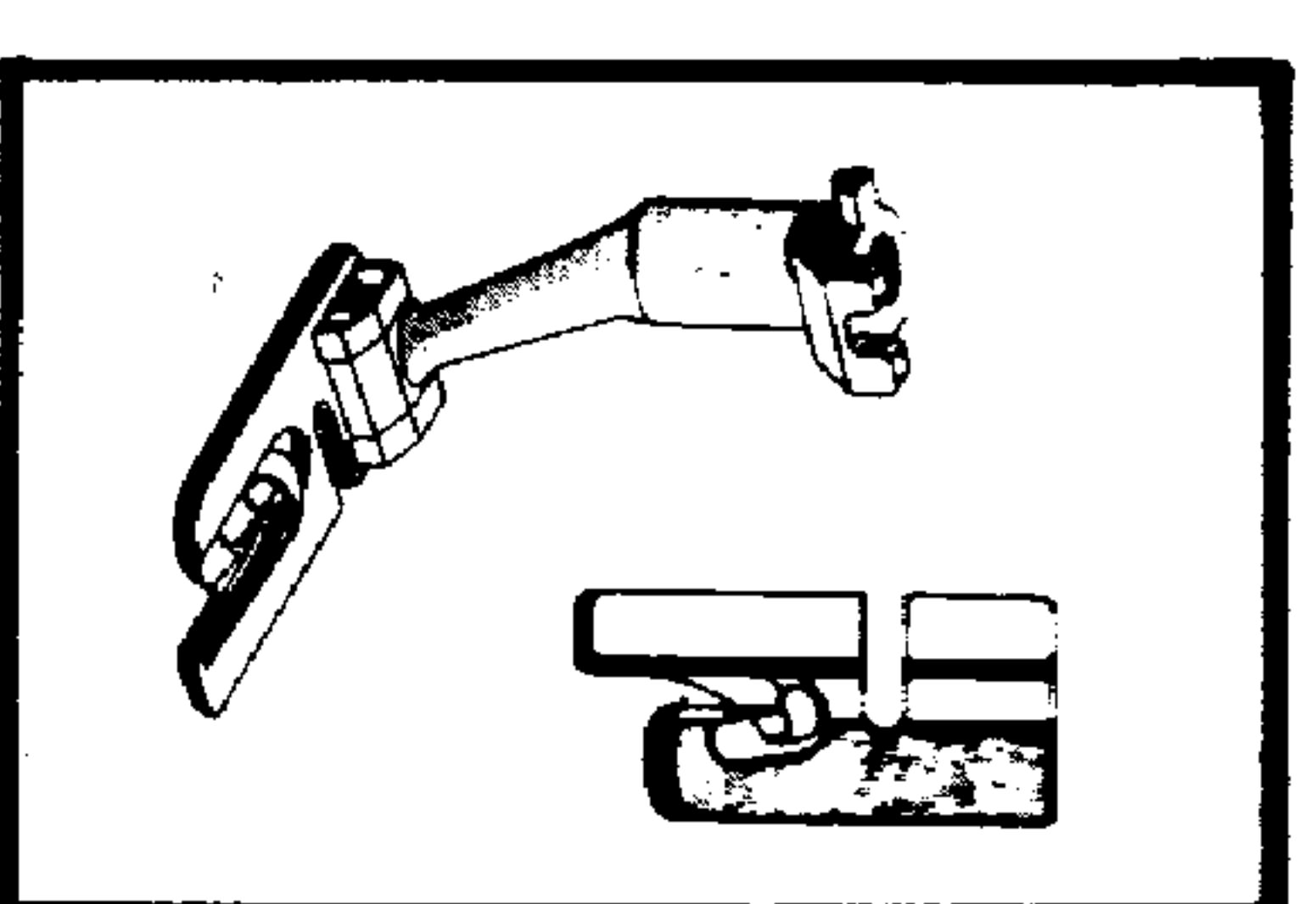

**NARROW HEMMER FOOT**  
For making  $\frac{1}{4}$ " hems.  
No. 530648  
For all models.

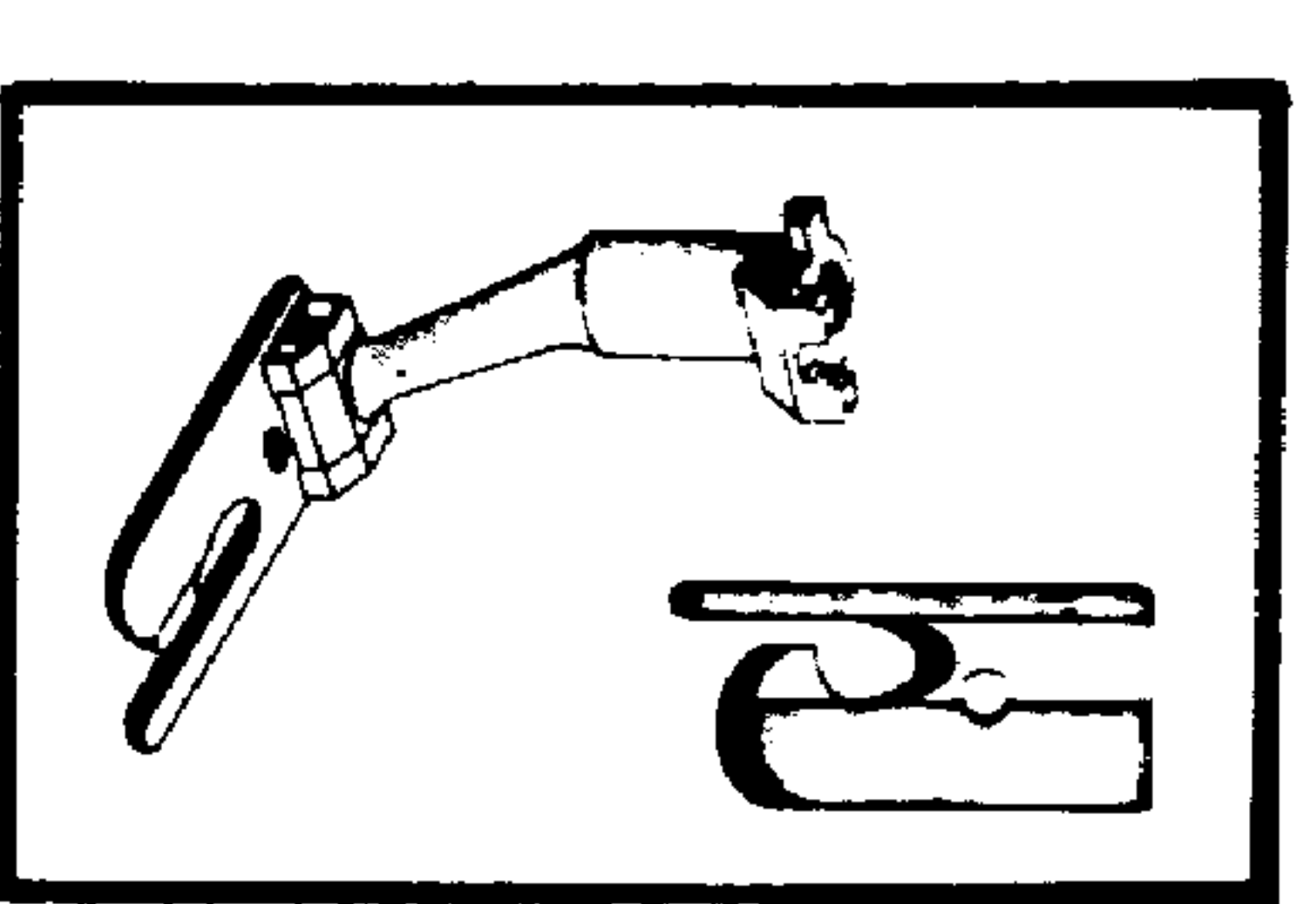

**LAP HEMMER FOOT (also called RUN & FELL)**  
For joining two pieces of material with a flat seam.  
No. 530613  
For all models.

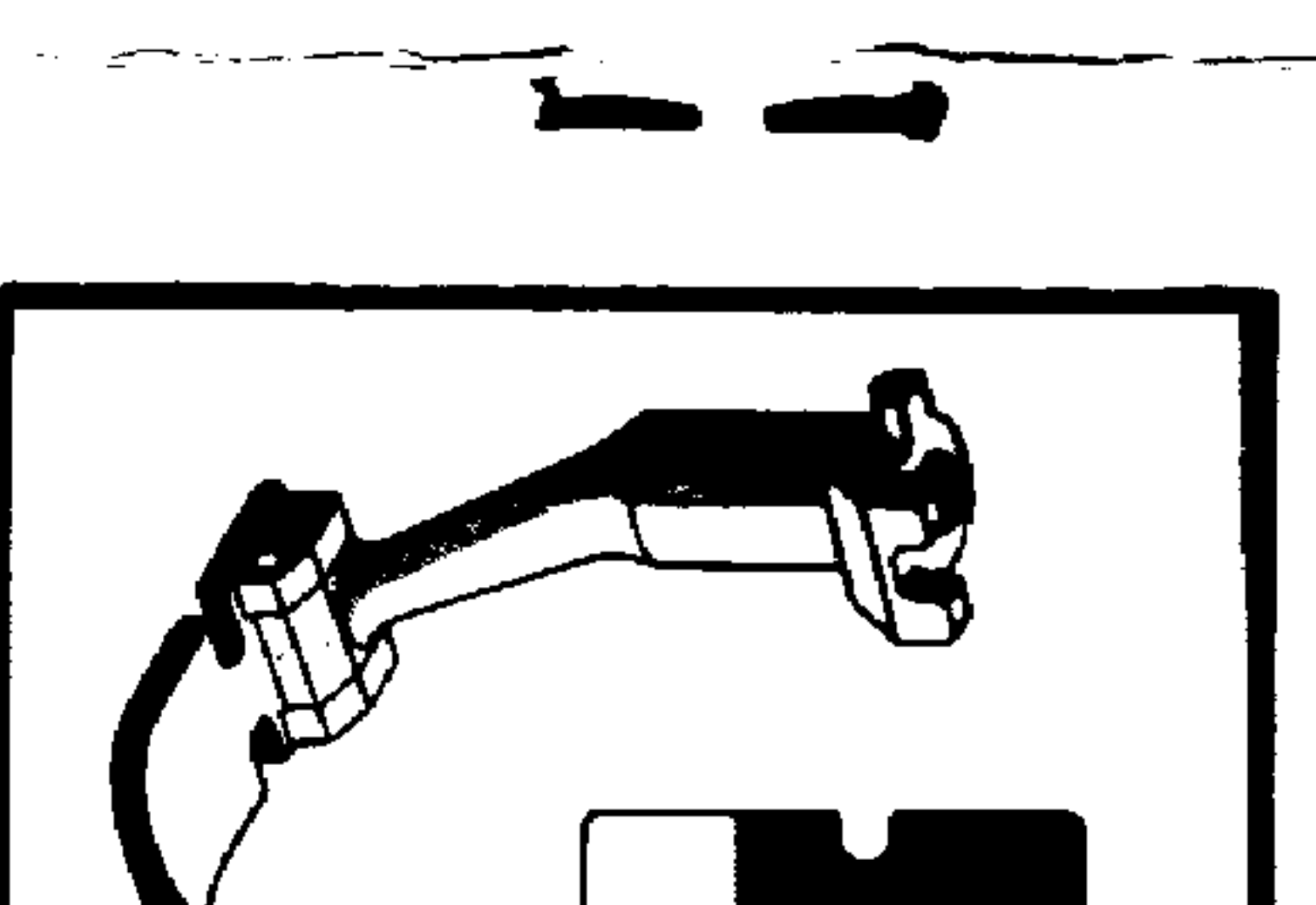

**DOUBLE ZIP FOOT**  
For inserting zips using needle position so enabling stitching left or right of foot.  
No. 631603  
For Swing Needle and Automatic Models only.

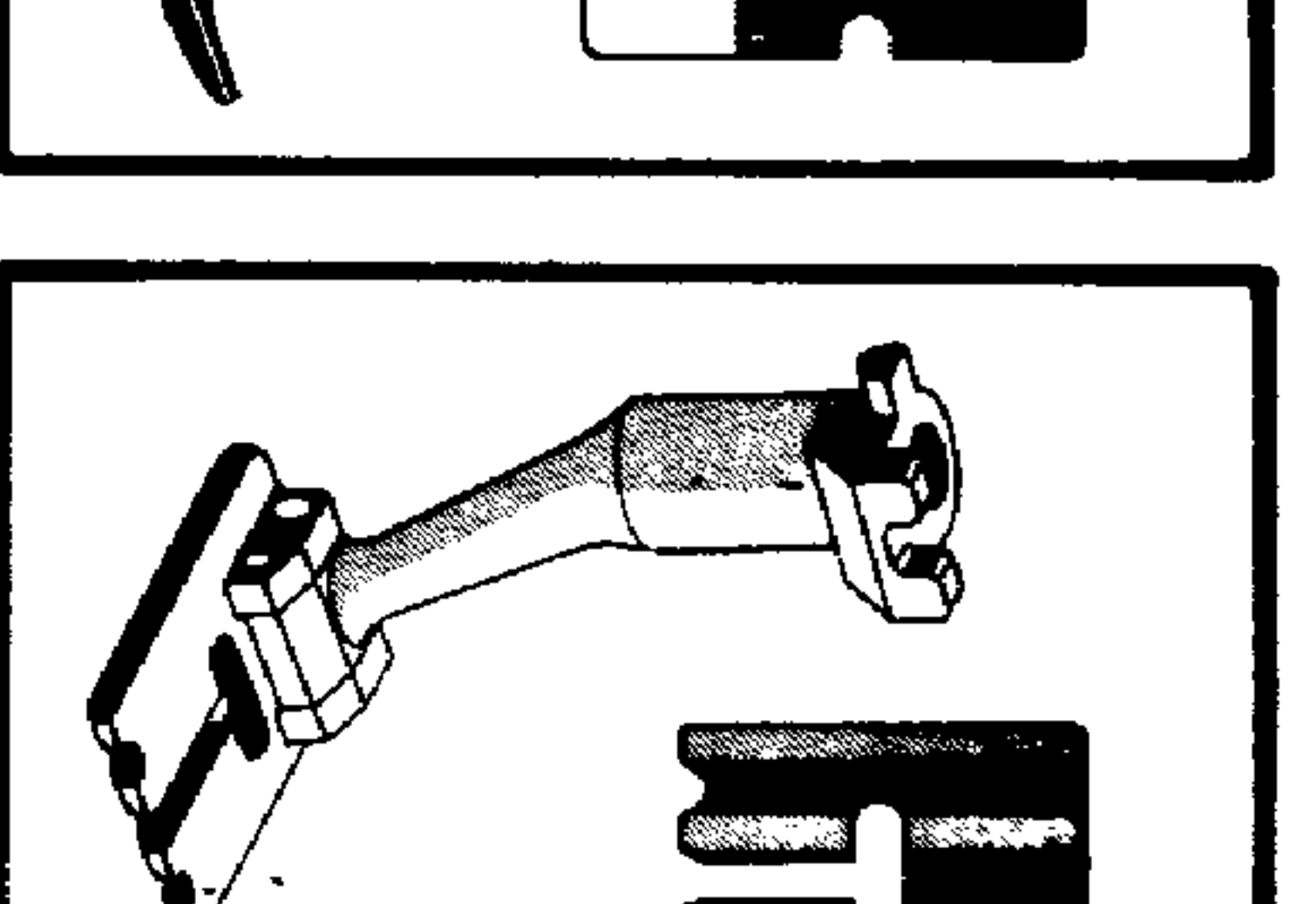

**PIN TUCK FOOT**  
3 Groove.  
For pintucking with or without cord with 4 mm. twin needle.  
No. 530632  
For all models.

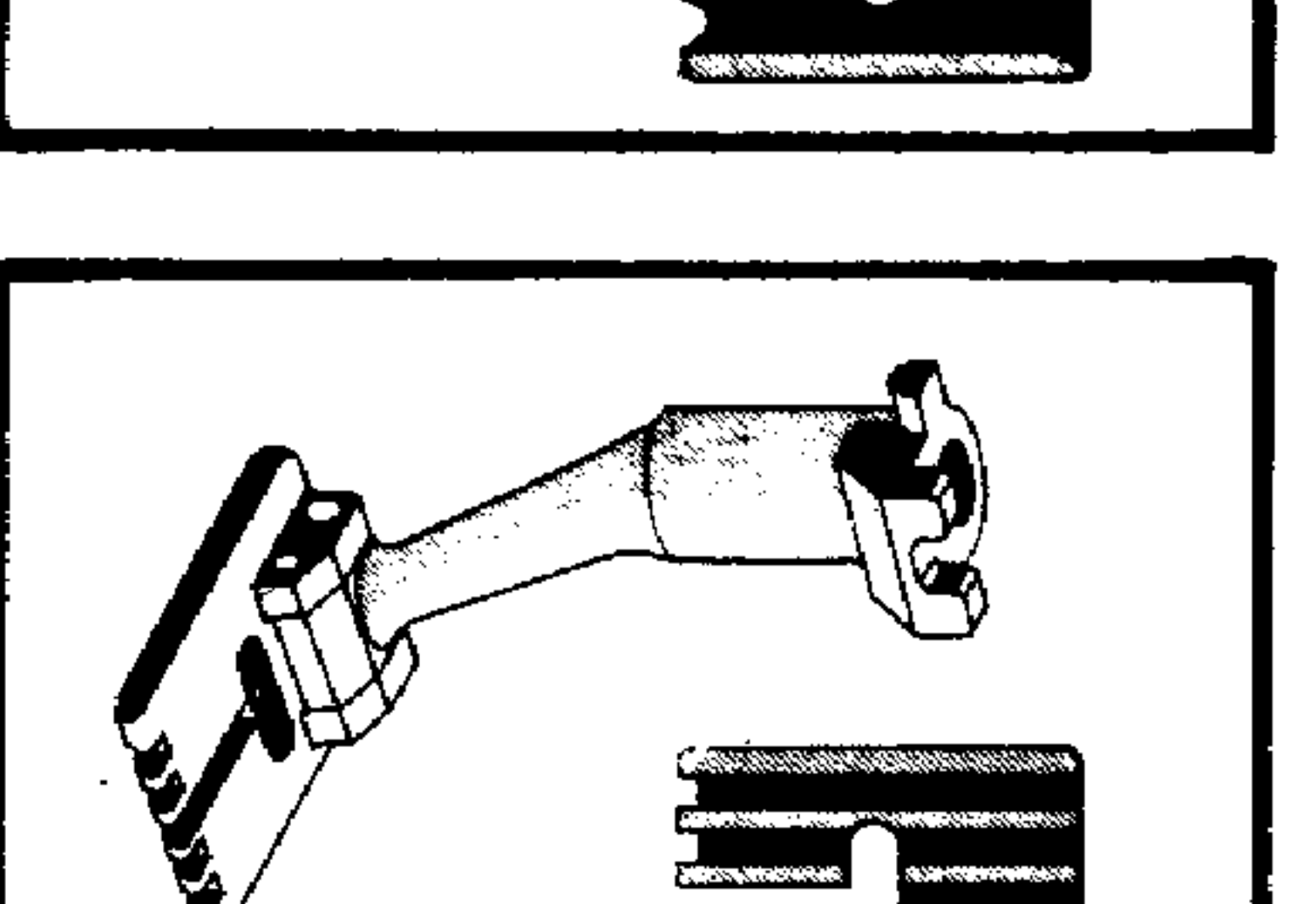

**PIN TUCK FOOT**  
5 Groove.  
For pintucking with or without cord with 3mm. twin needle.  
No. 530634  
For all models.

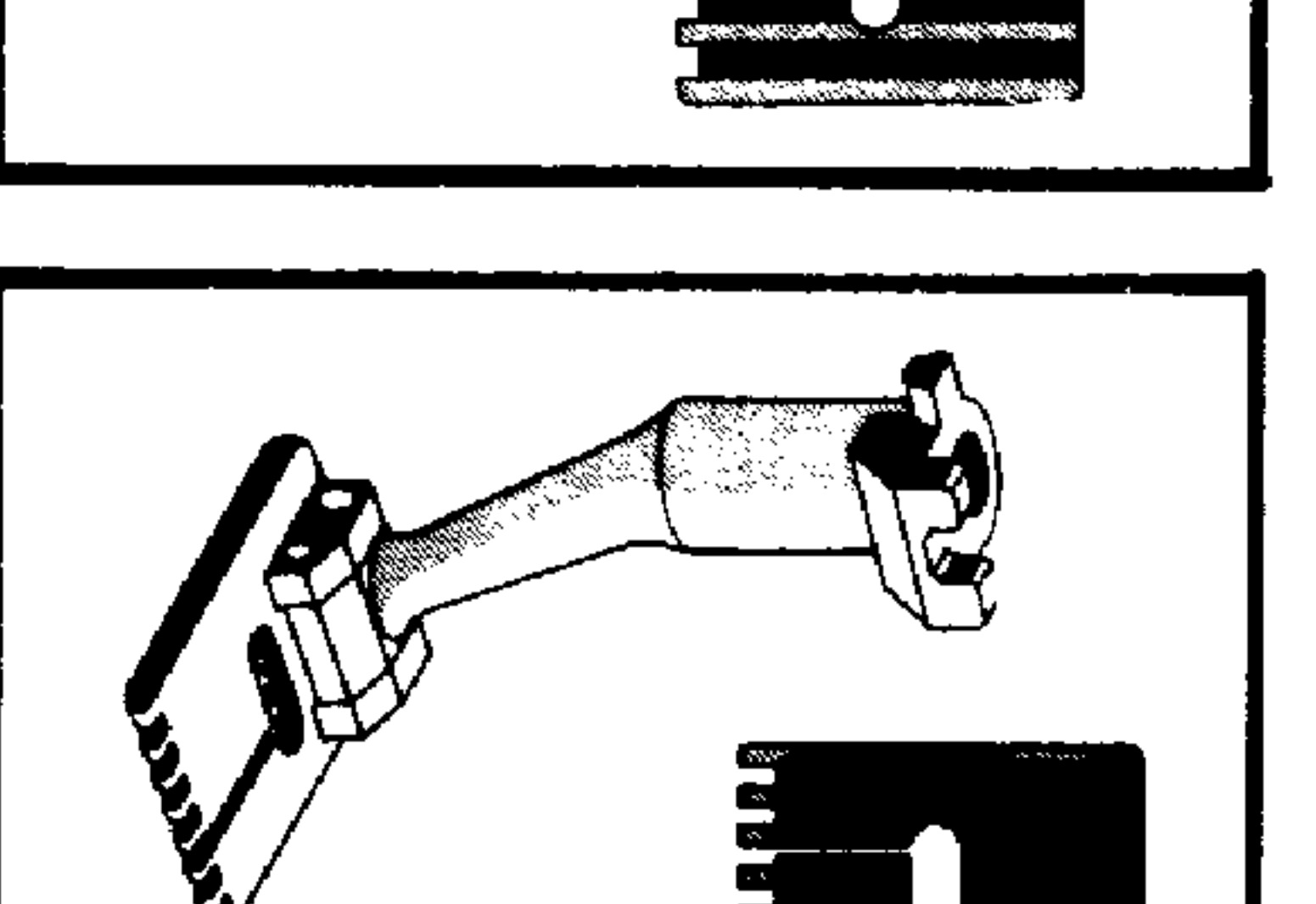

**PIN TUCK FOOT**  
7 Groove.  
For pintucking with or without cord with 2 mm. twin needle.  
No. 530636  
For all models.

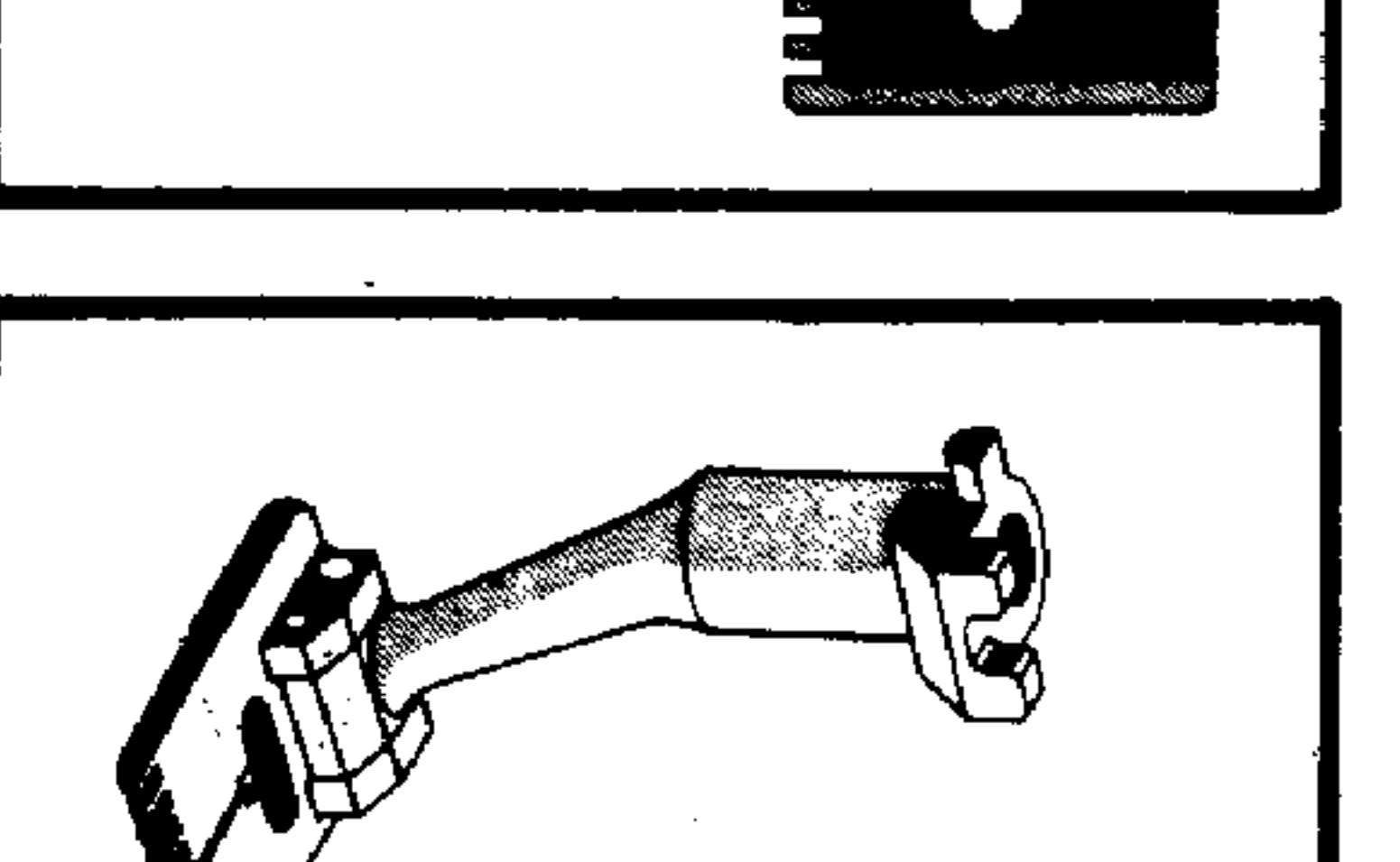

**PIN TUCK FOOT**  
9 Groove.  
For special fine pin with or without cord with 1.5 mm. twin needle.  
No. 530638  
For all models.

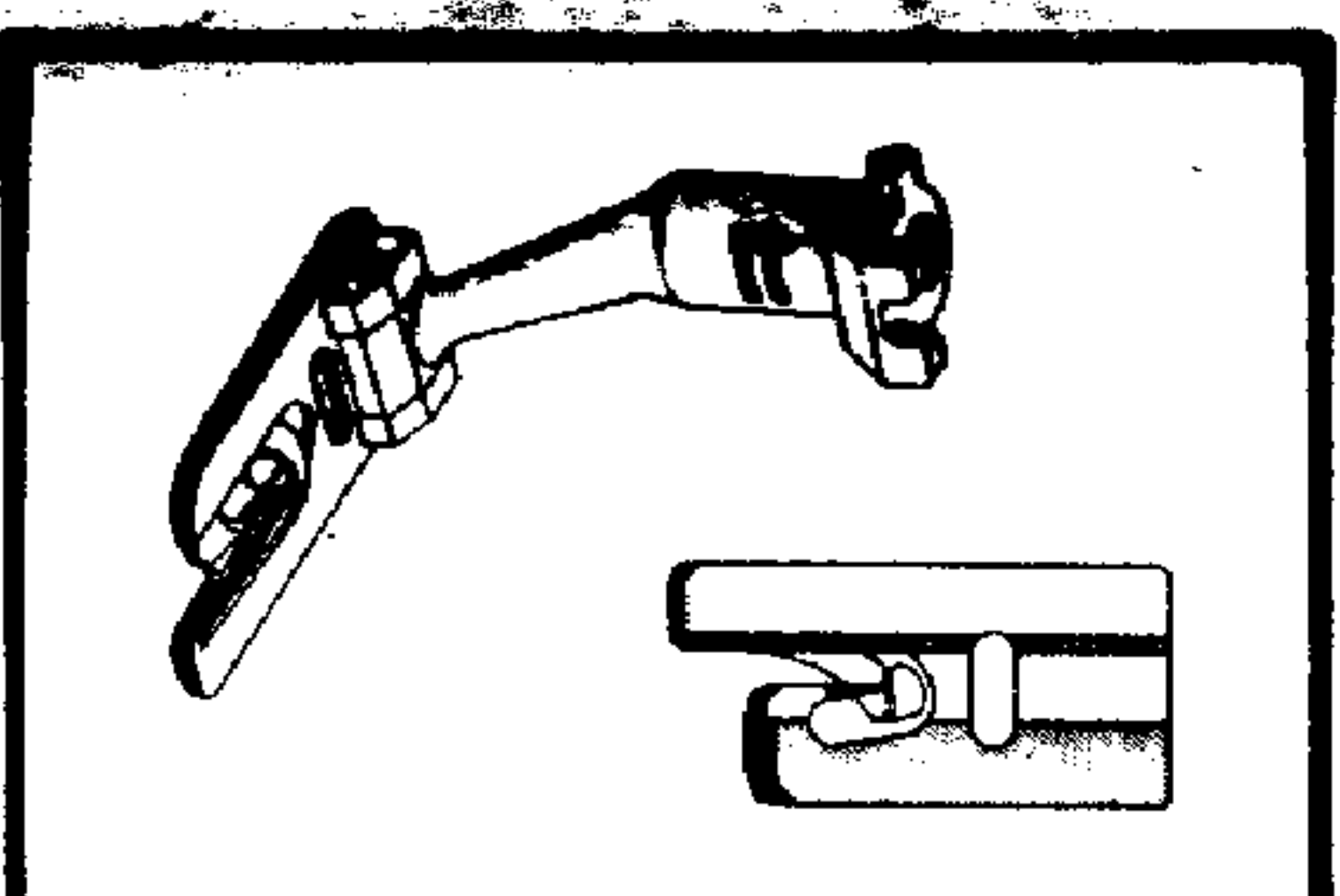

**ROLL AND SHELL HEMMER FOOT**  
For making a shell edge or hemming edges with decorative zig zag stitches on either side of hem.  
No. 530611  
For Swing Needle and Automatic Models.

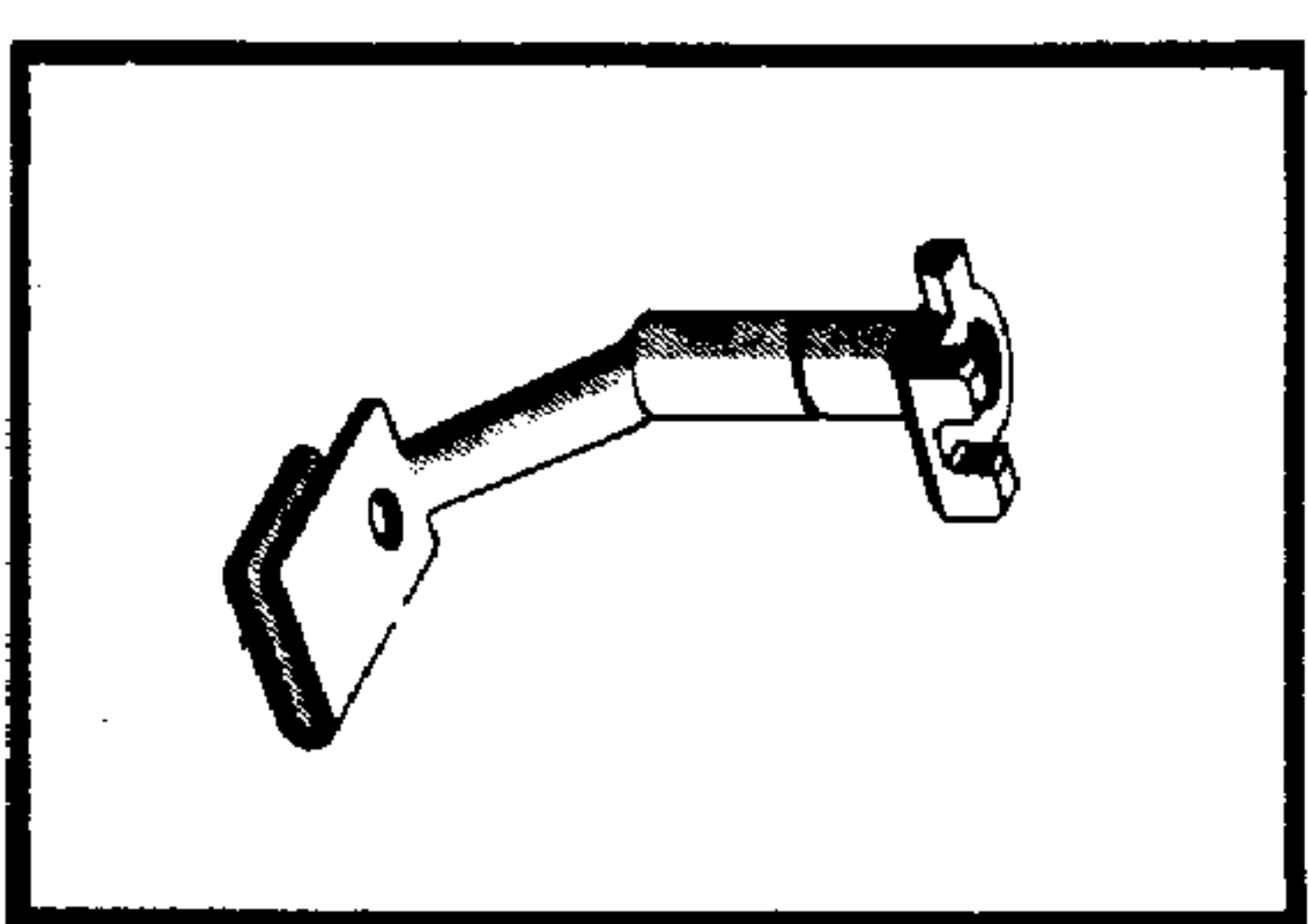

**GATHERING FOOT**  
For gathering single piece of material or one piece on to another.  
No. 530646  
For all models.

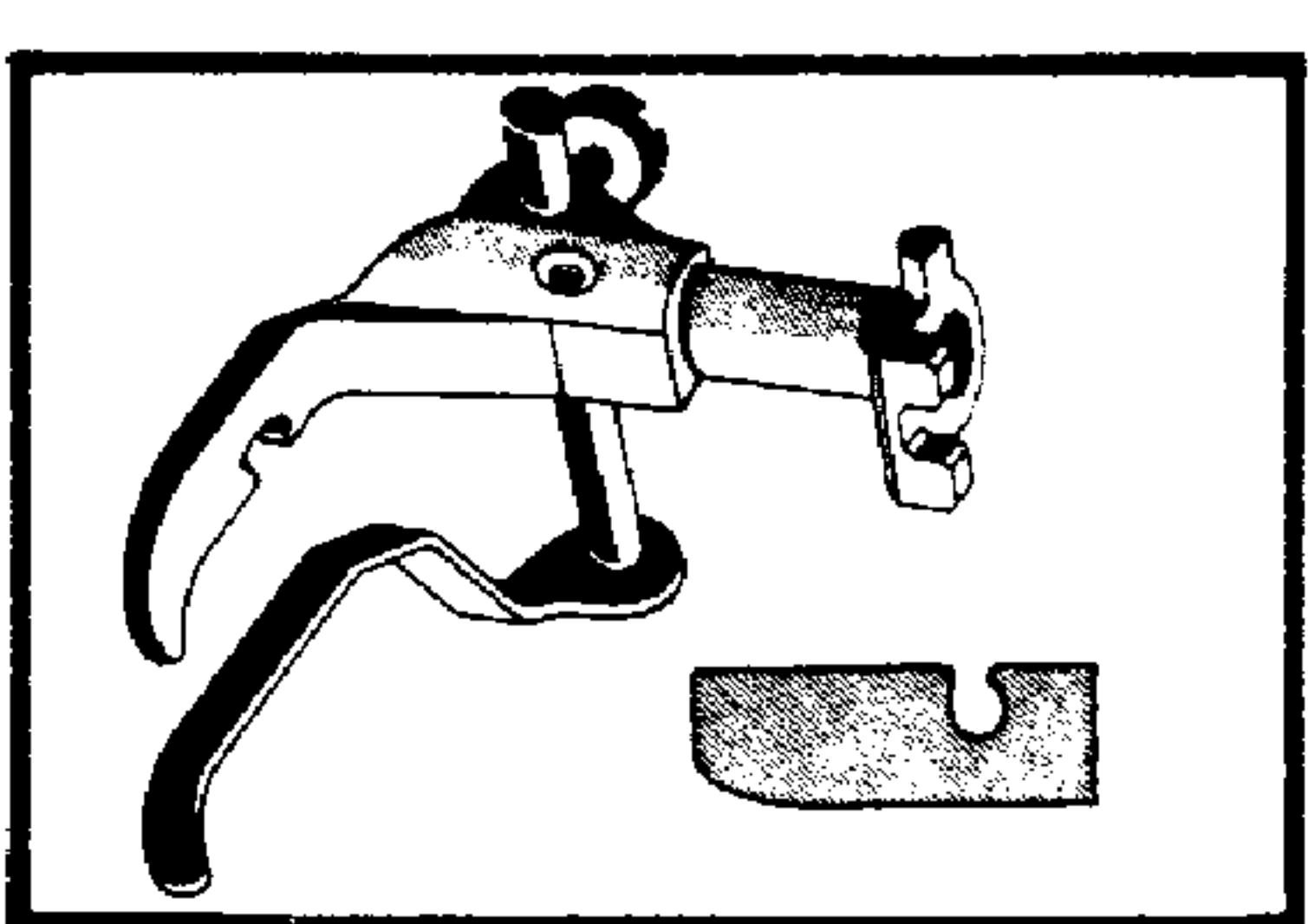

**EDGE FOOT WITH ADJUSTABLE GUIDE**  
For straight stitch sewing on edge of material; piping or quilting.  
No. 530615  
For all models.

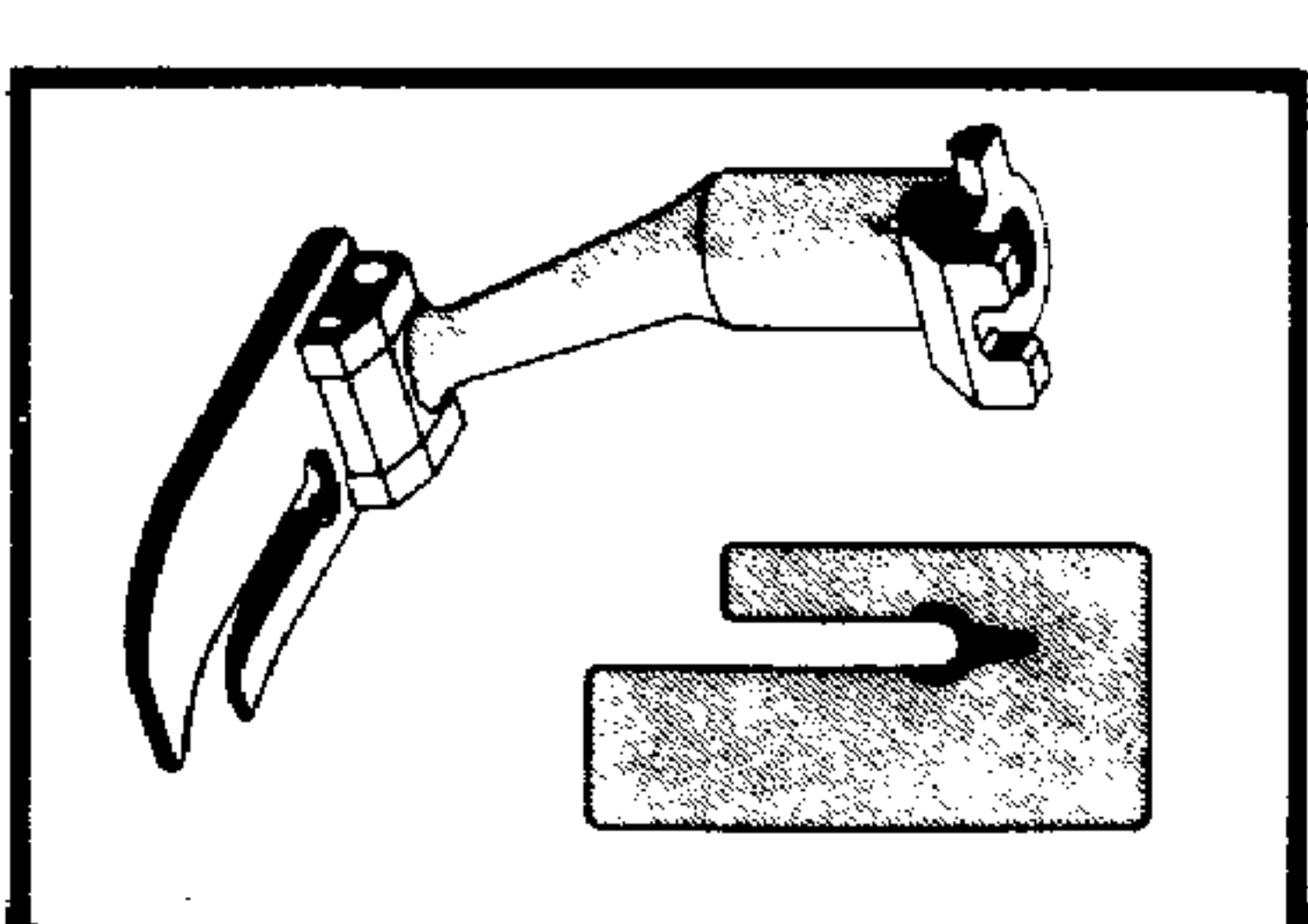

**PLAIN STITCH HINGED PRESSER FOOT**  
For straight stitch sewing including seaming.  
No. 530644  
For all models.

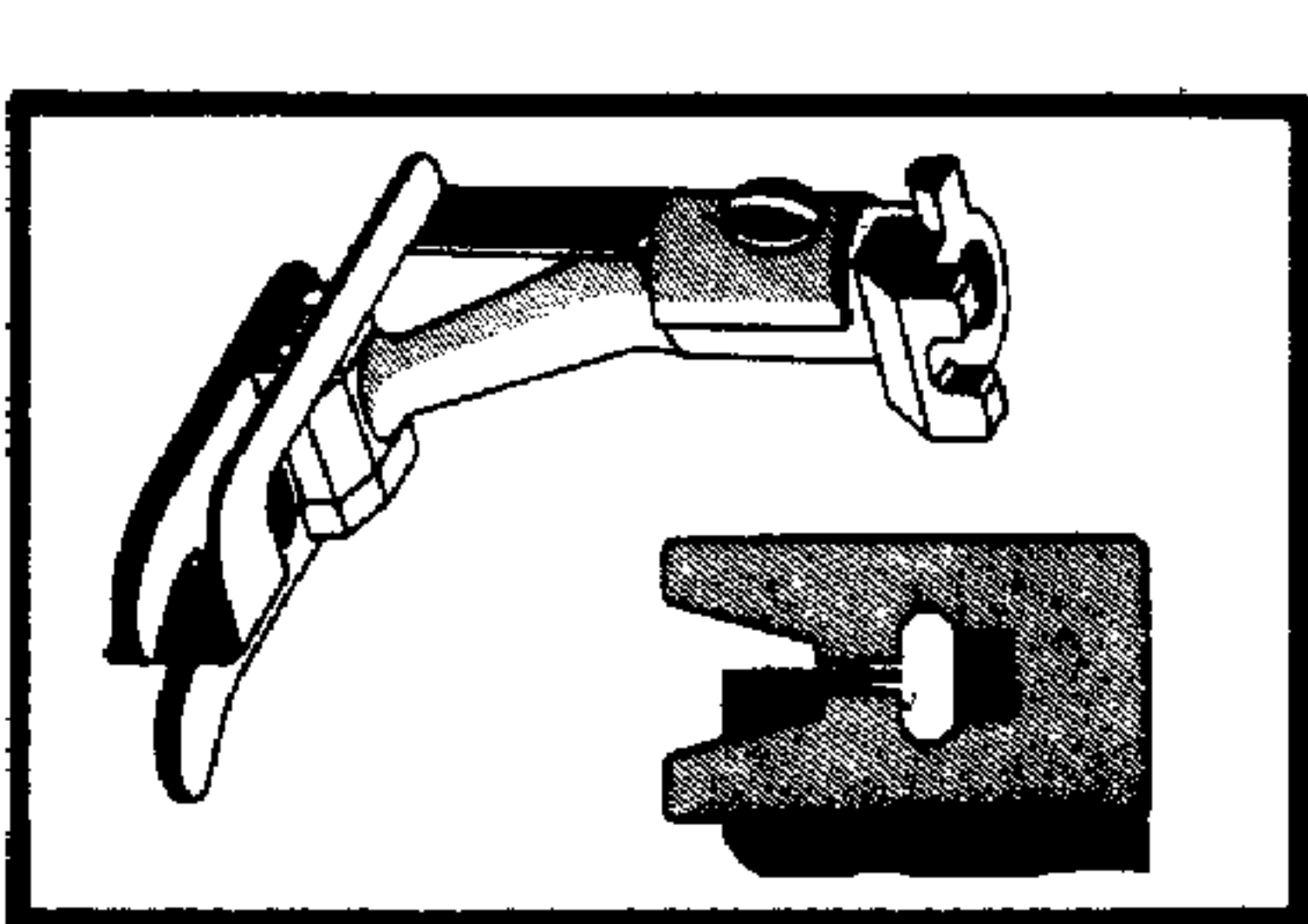

**BLINDSTITCH FOOT**  
For blind stitching hems, etc.  
No. 530682  
For Swing Needle and Automatic Models only.

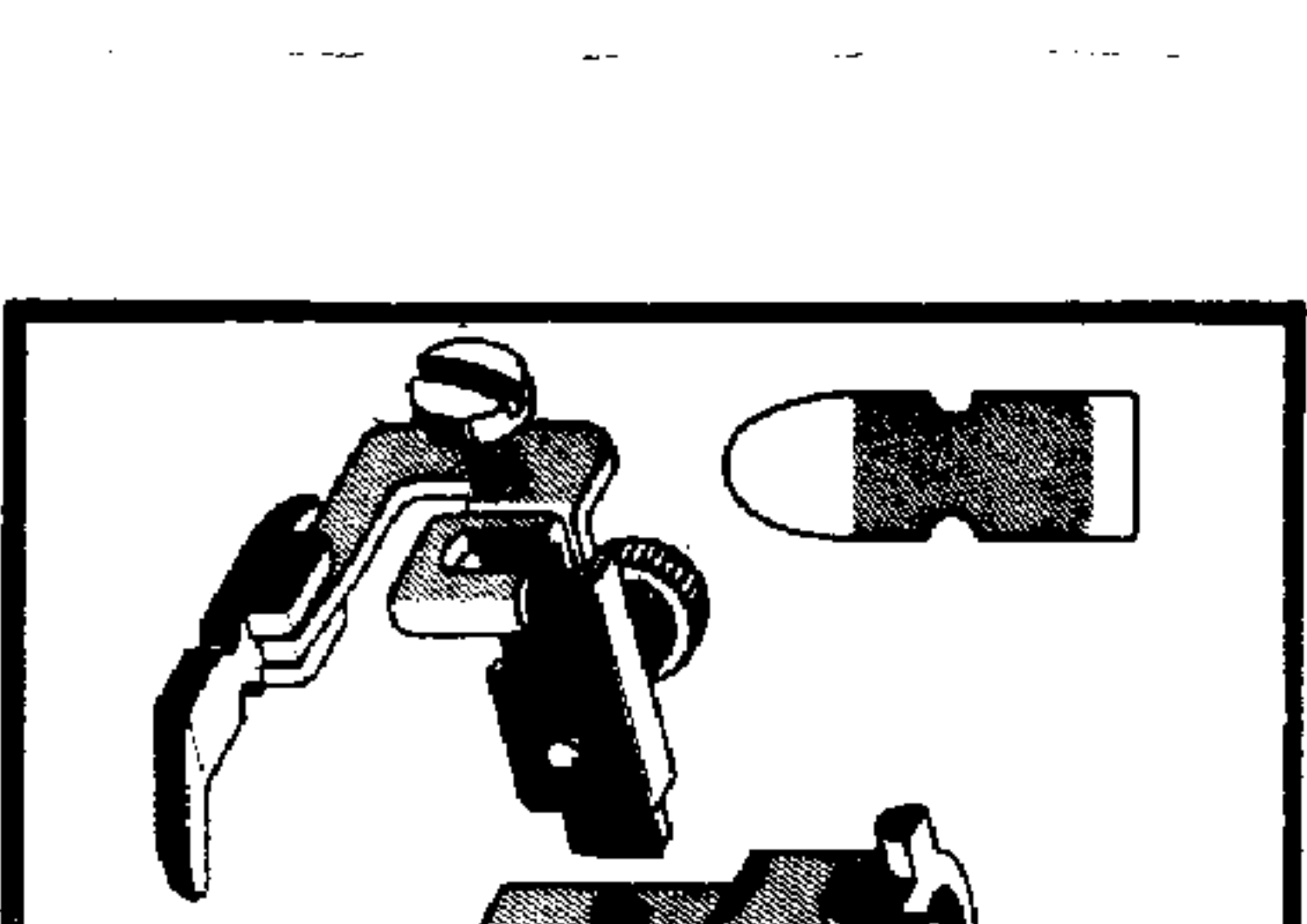

**ADJUSTABLE ZIP FOOT**  
complete with adaptor.  
For inserting zips.  
No. 531612  
For all models.

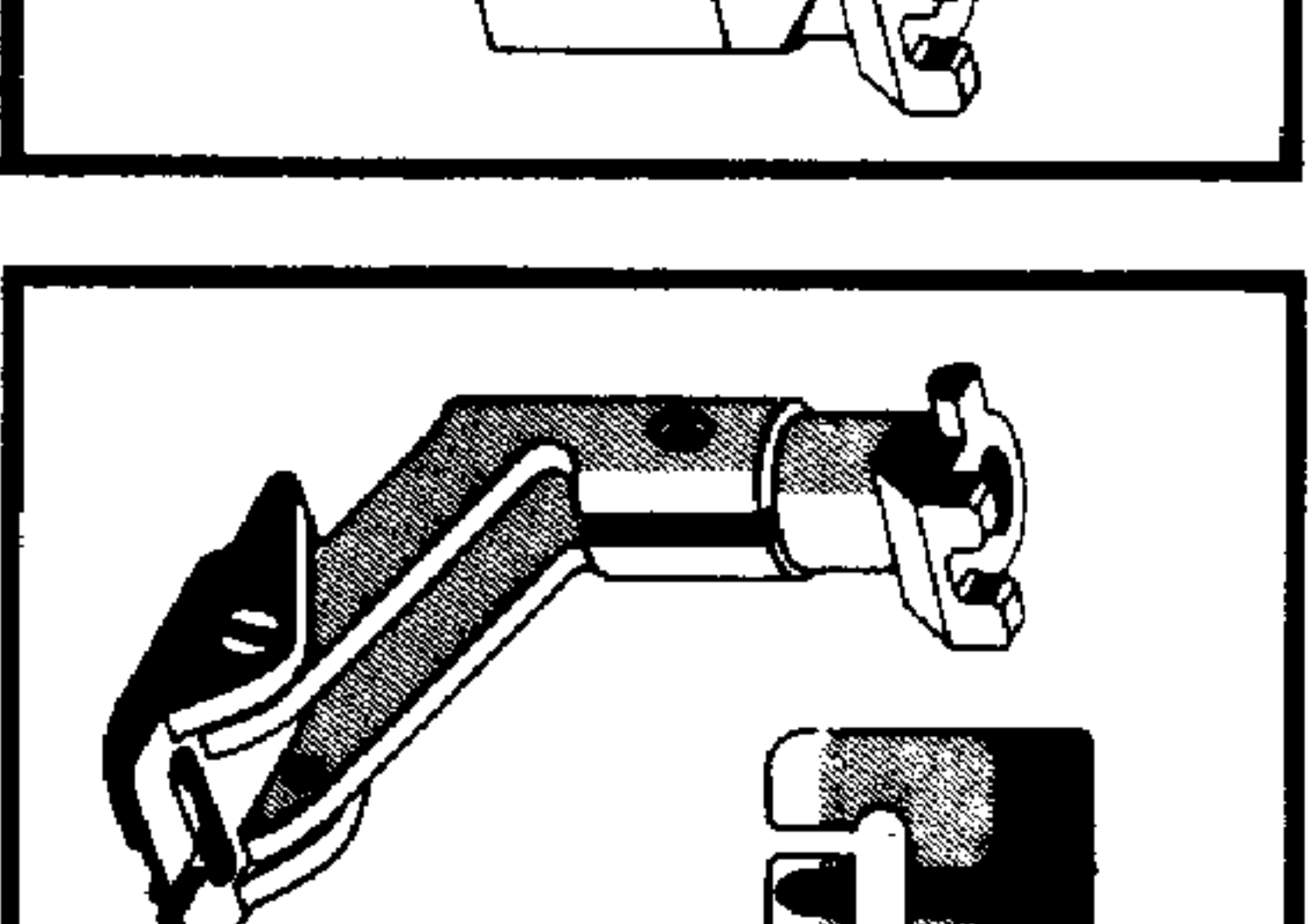

**APPLIQUE FOOT**  
For applique sewing.  
No. 630677  
For all Swing Needle and Automatic Models.

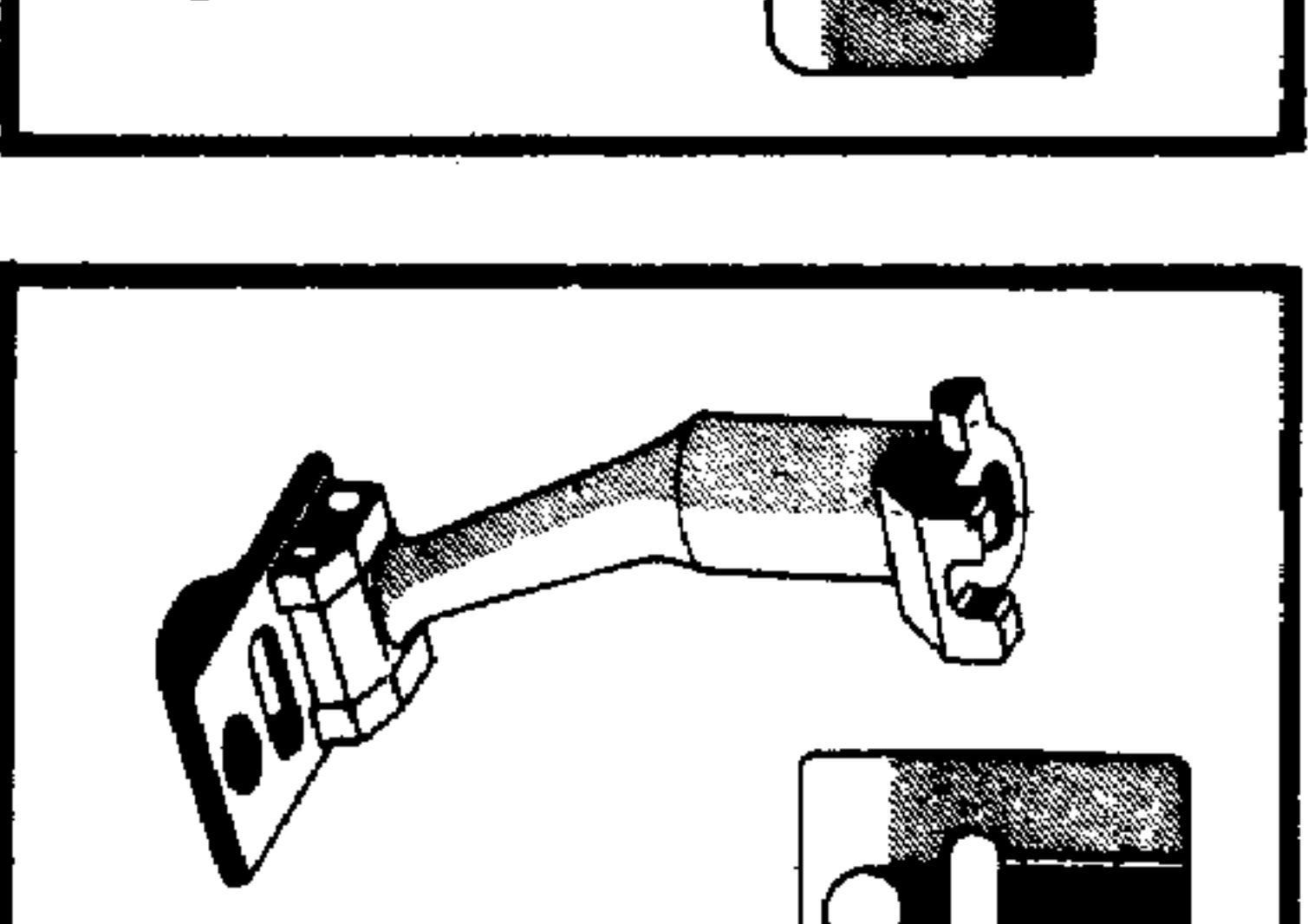

**BRAIDING FOOT**  
For inserting braid.  
No. 540617  
For all Swing needle and Automatic Models.

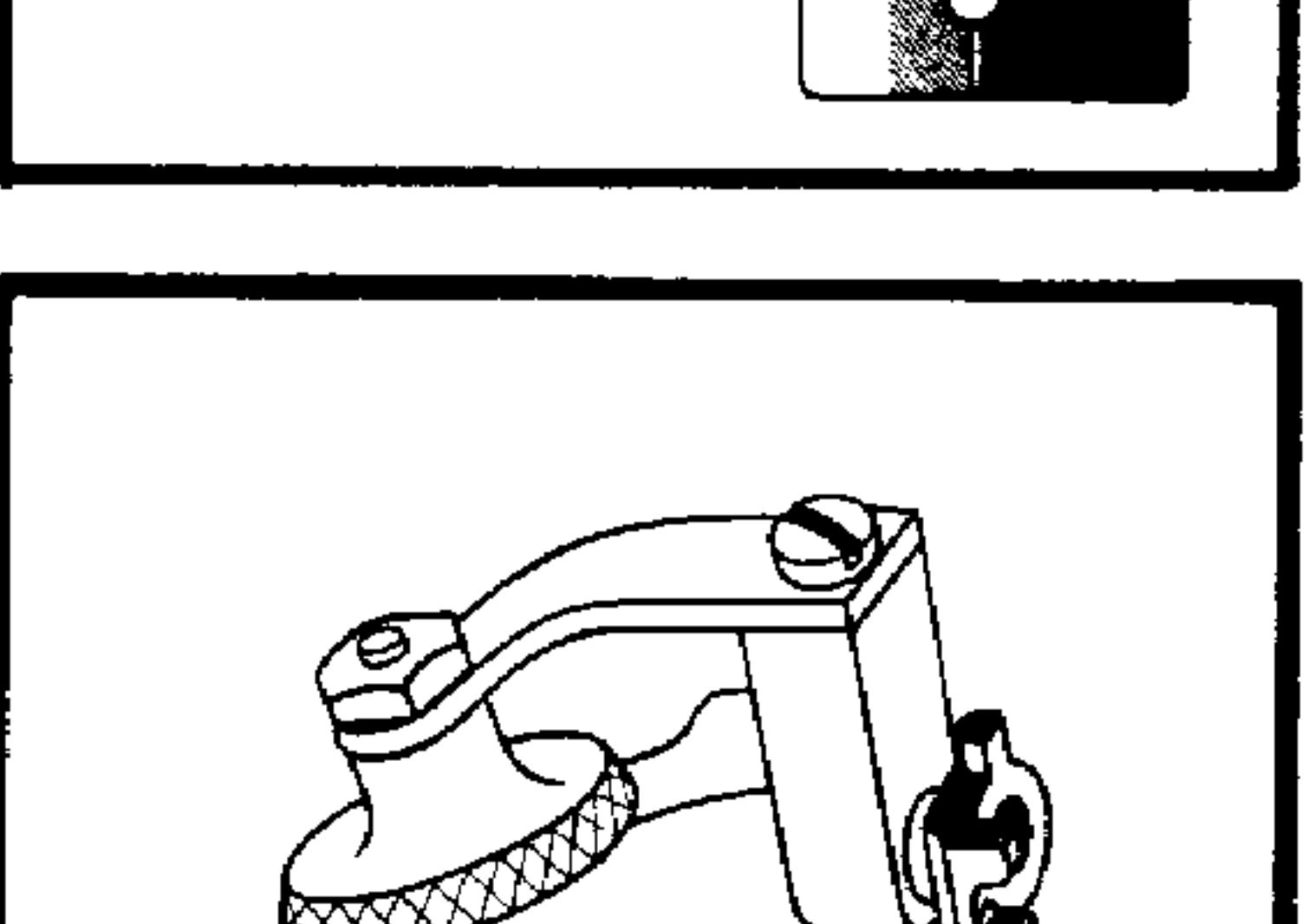

**ROLLER FOOT**  
For sewing light weight leather.  
For all models.

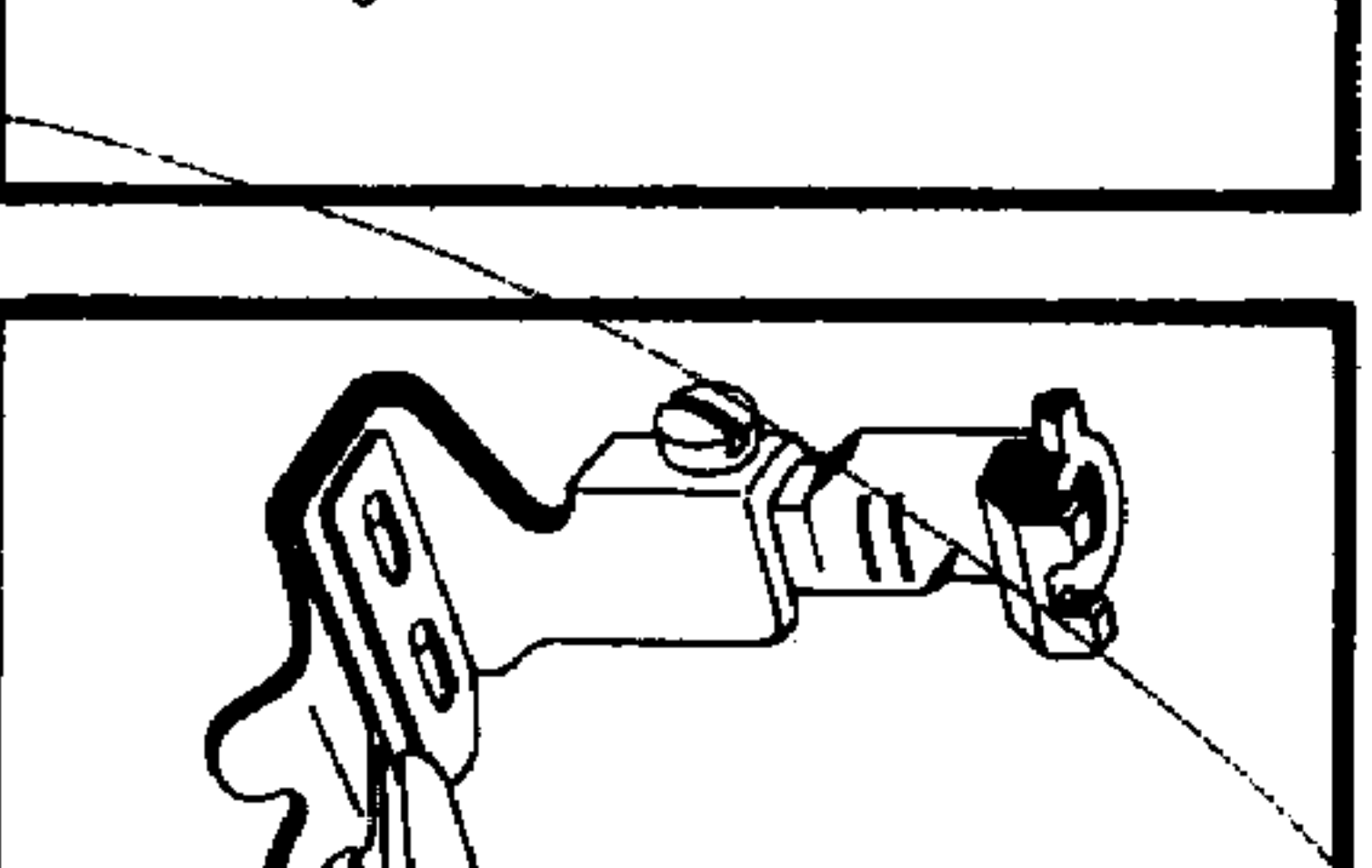

**BINDER FOOT**  
complete with adaptor.  
For edging material  $\frac{3}{8}$ " bias binding.  
For all models.

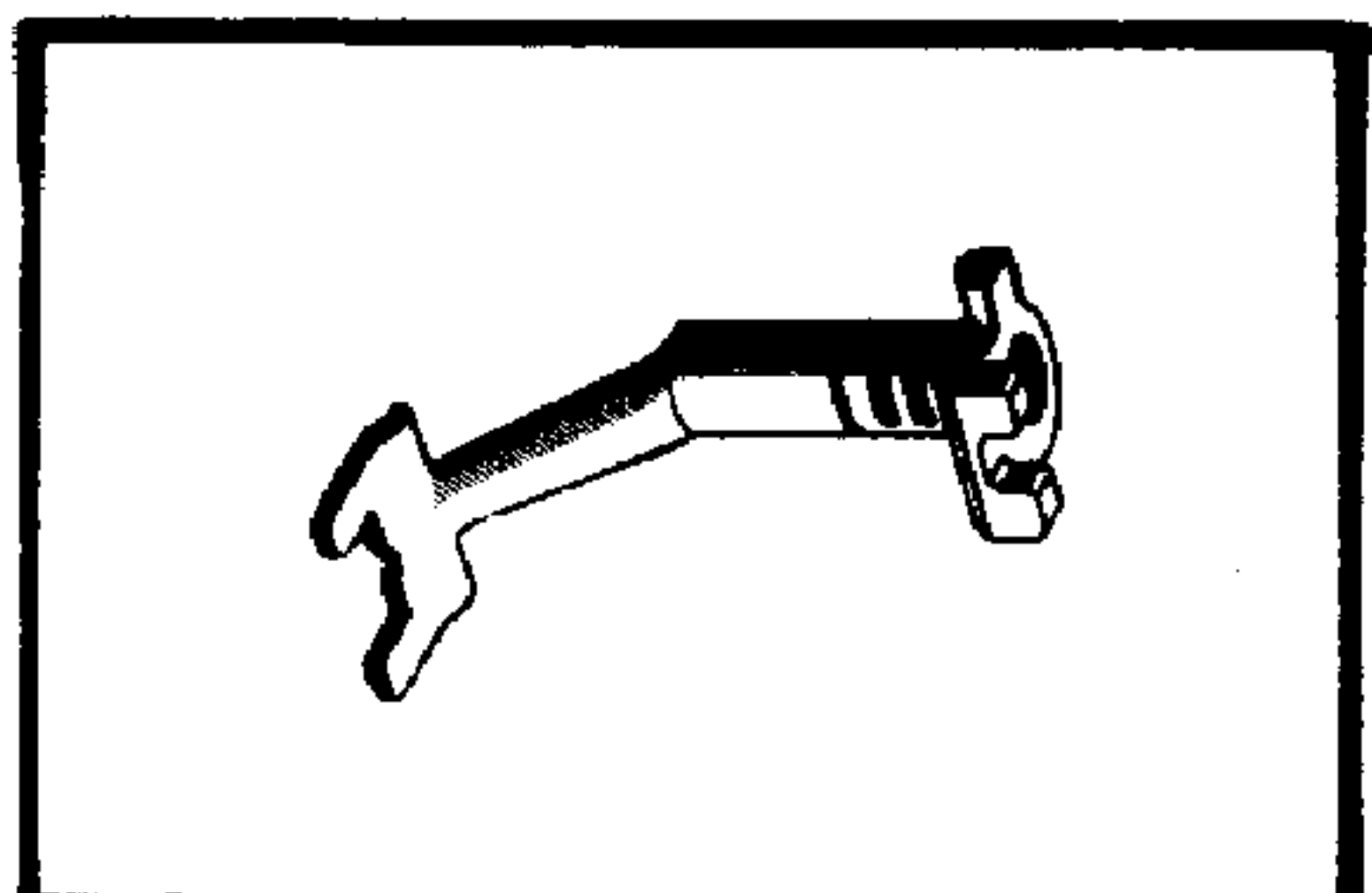

**BUTTON SEWING FOOT**  
For sewing on 2 and 4 hole buttons.  
No. 530620  
For Swing Needle and Automatic Models only.

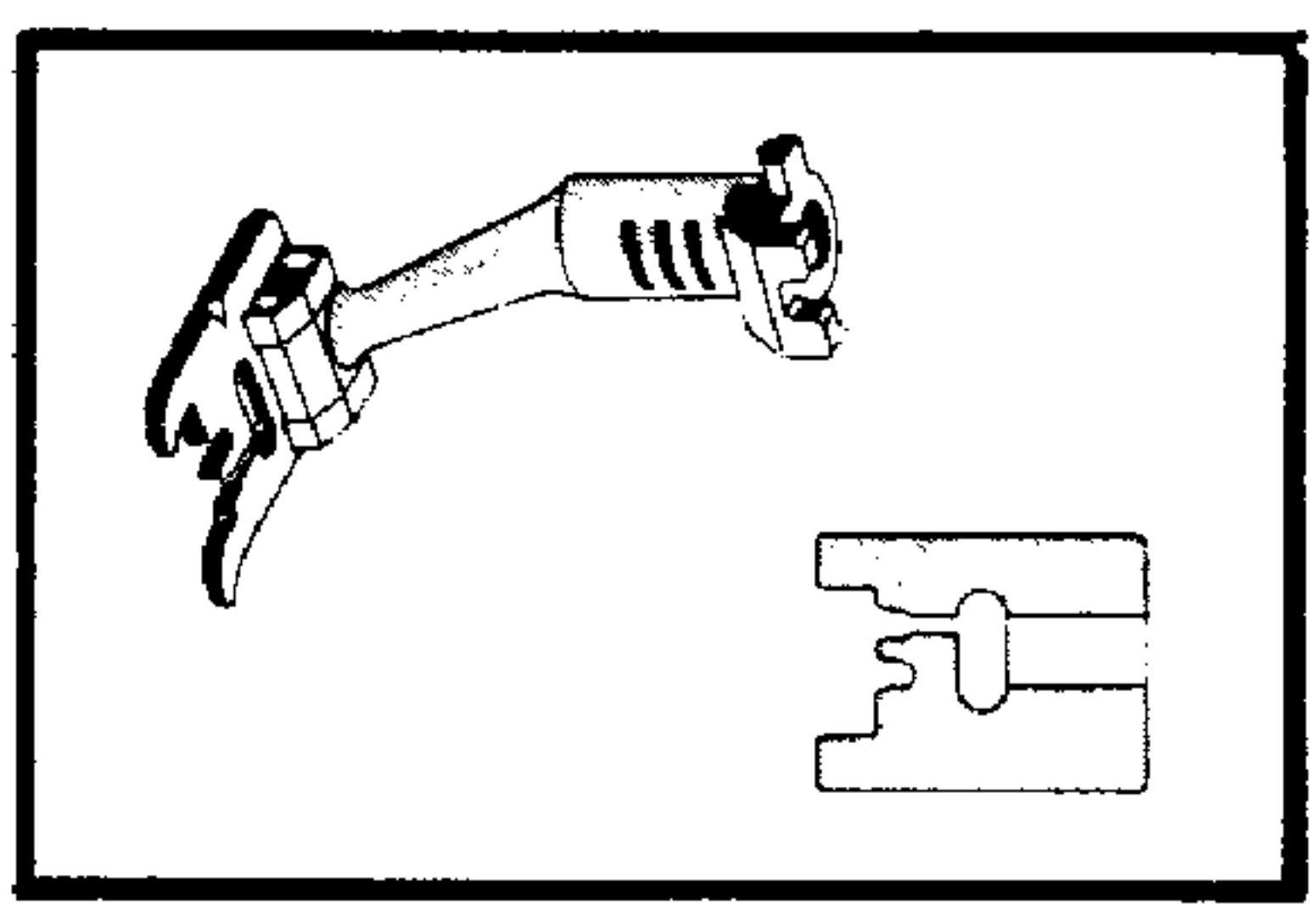

**BUTTONHOLE FOOT**  
For making Buttonholes non-automatically.  
No. 530618  
For all Swing Needle Models.

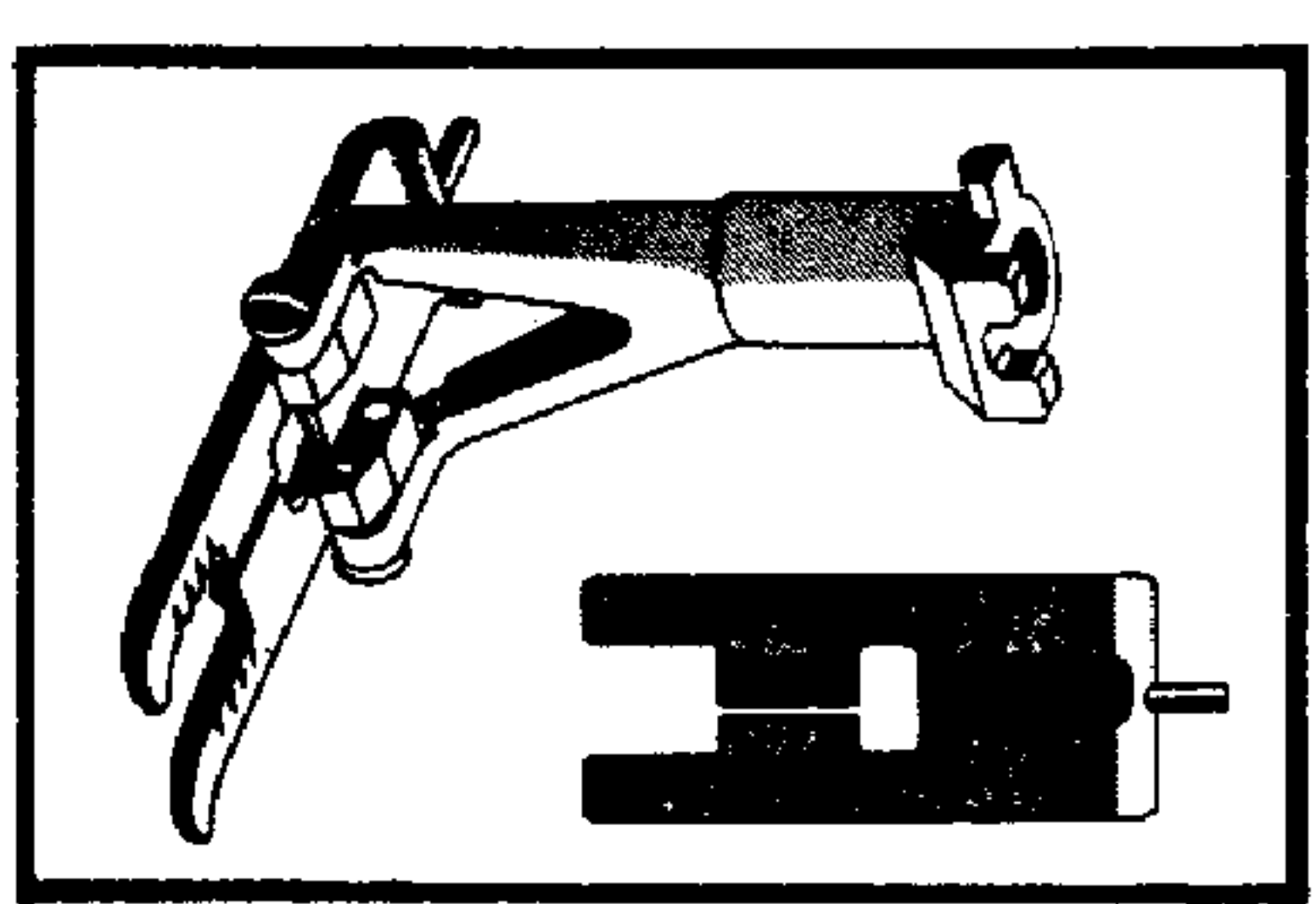

**AUTOMATIC BUTTONHOLE FOOT**  
For making Buttonholes automatically.  
No. 630618  
For Semi and Full Automatic Models only.

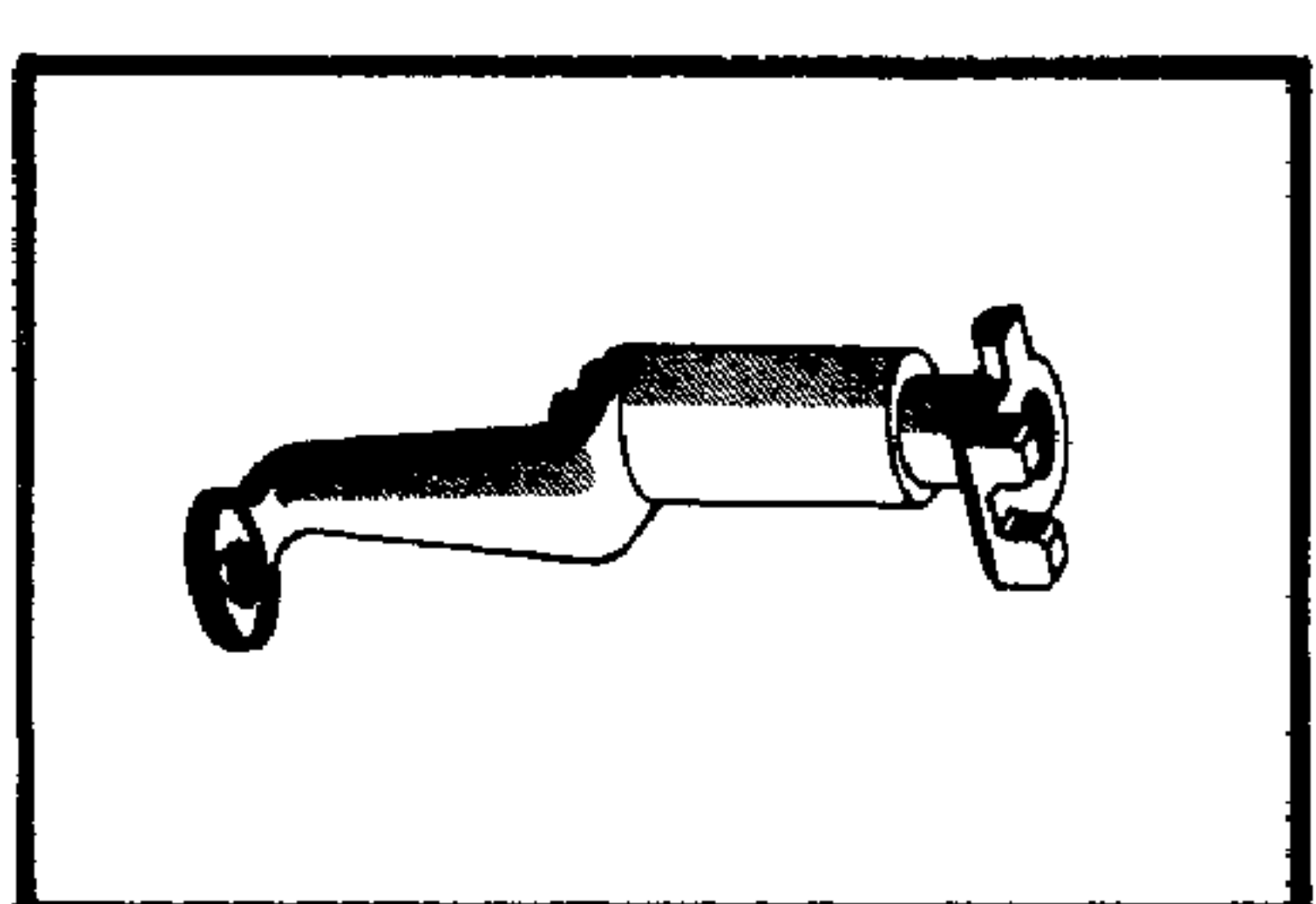

**COTTON DARNING FOOT**  
Spring loaded foot for darning of cotton and woven fabrics.  
No. 530670  
For all models.

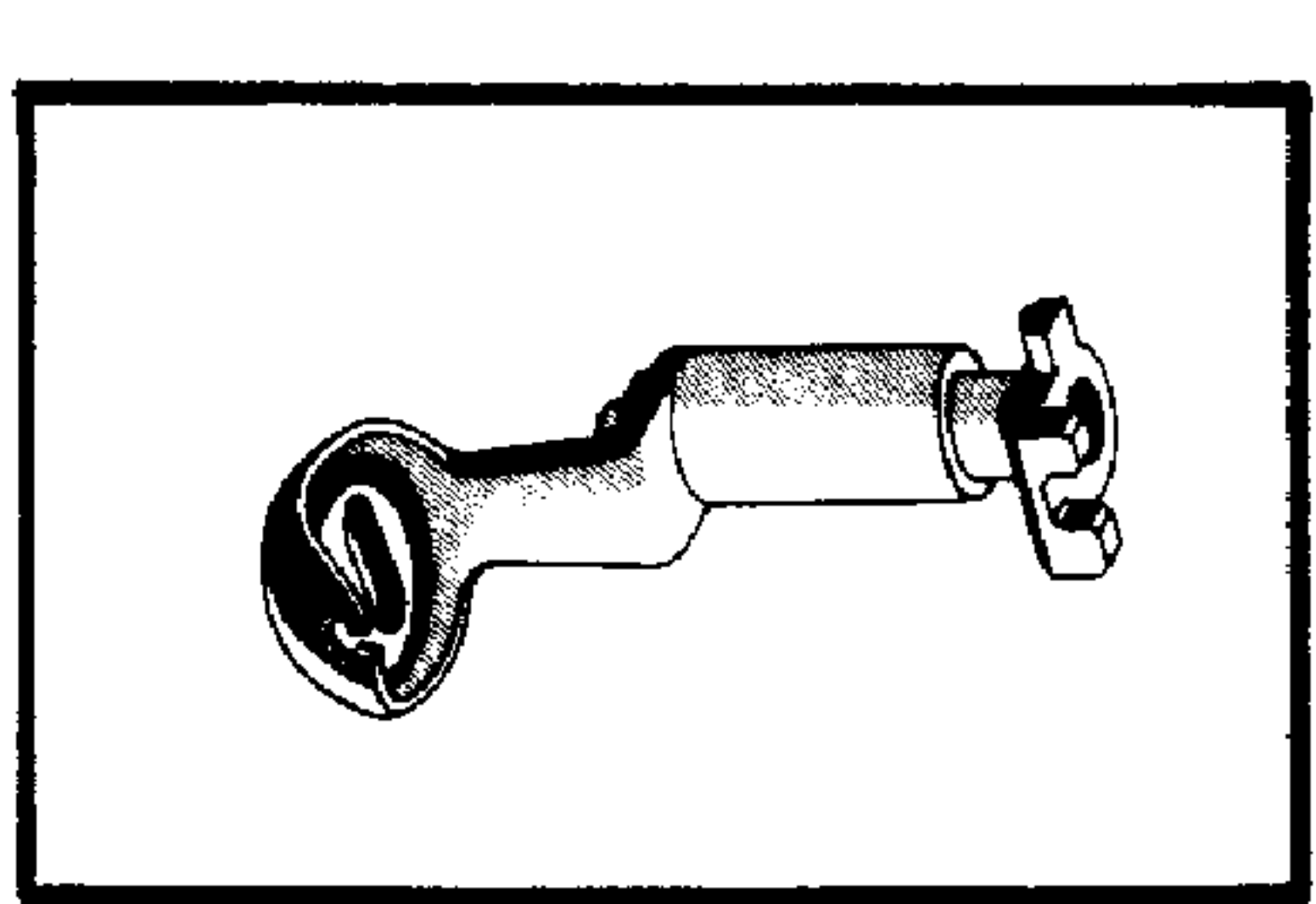

**WOOL DARNING FOOT**  
Spring loaded foot for darning of woollens and knitted fabrics and for free hand zig zag embroidery and monograms.  
No. 530629  
For Swing Needle and Automatic Models only.

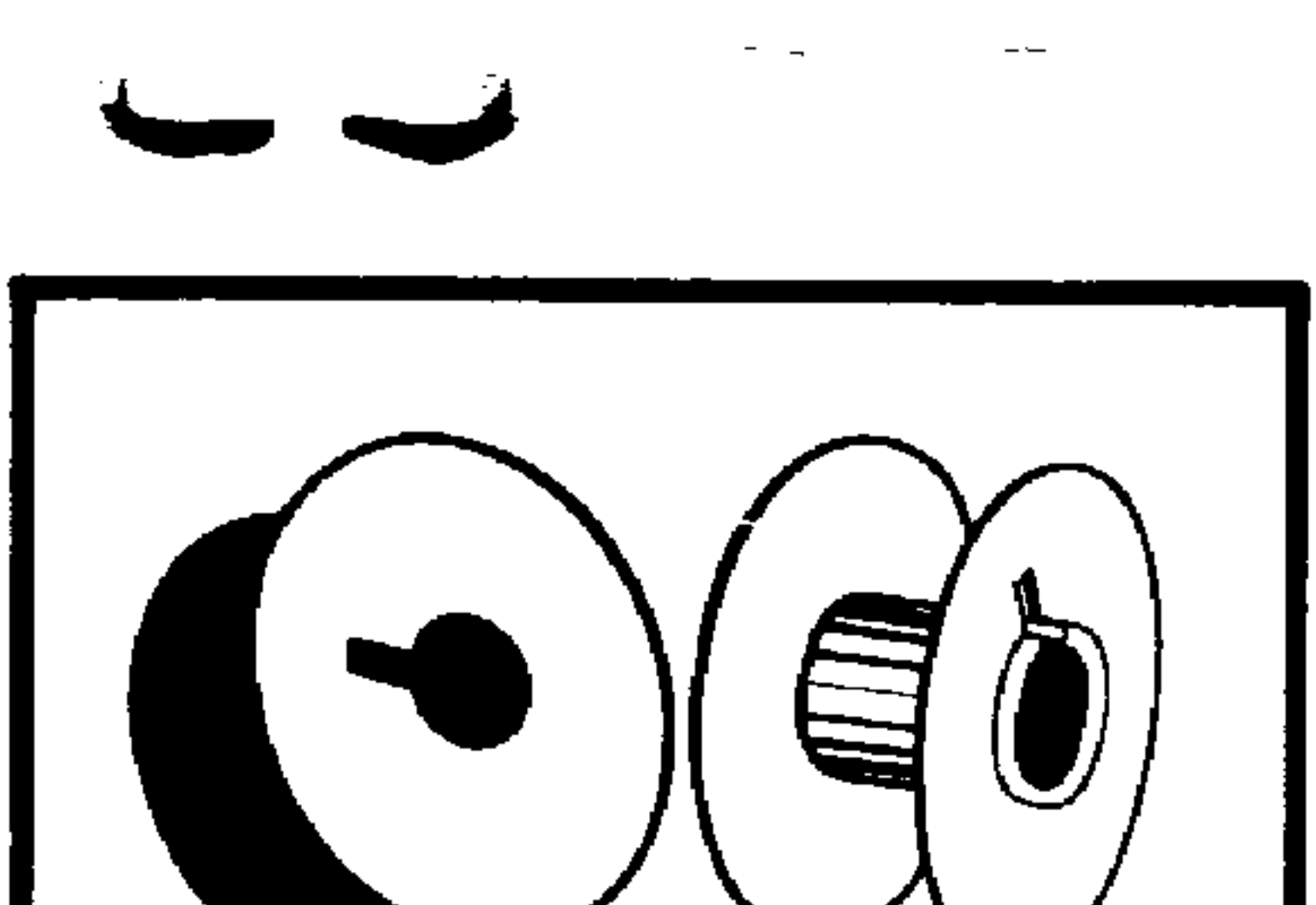

**BOBBINS**  
No. 530761.  
For all Free Arm Models also Flat Bed Models 610 and 710.  
No. 540761.  
For all Flat Bed Models except as above.

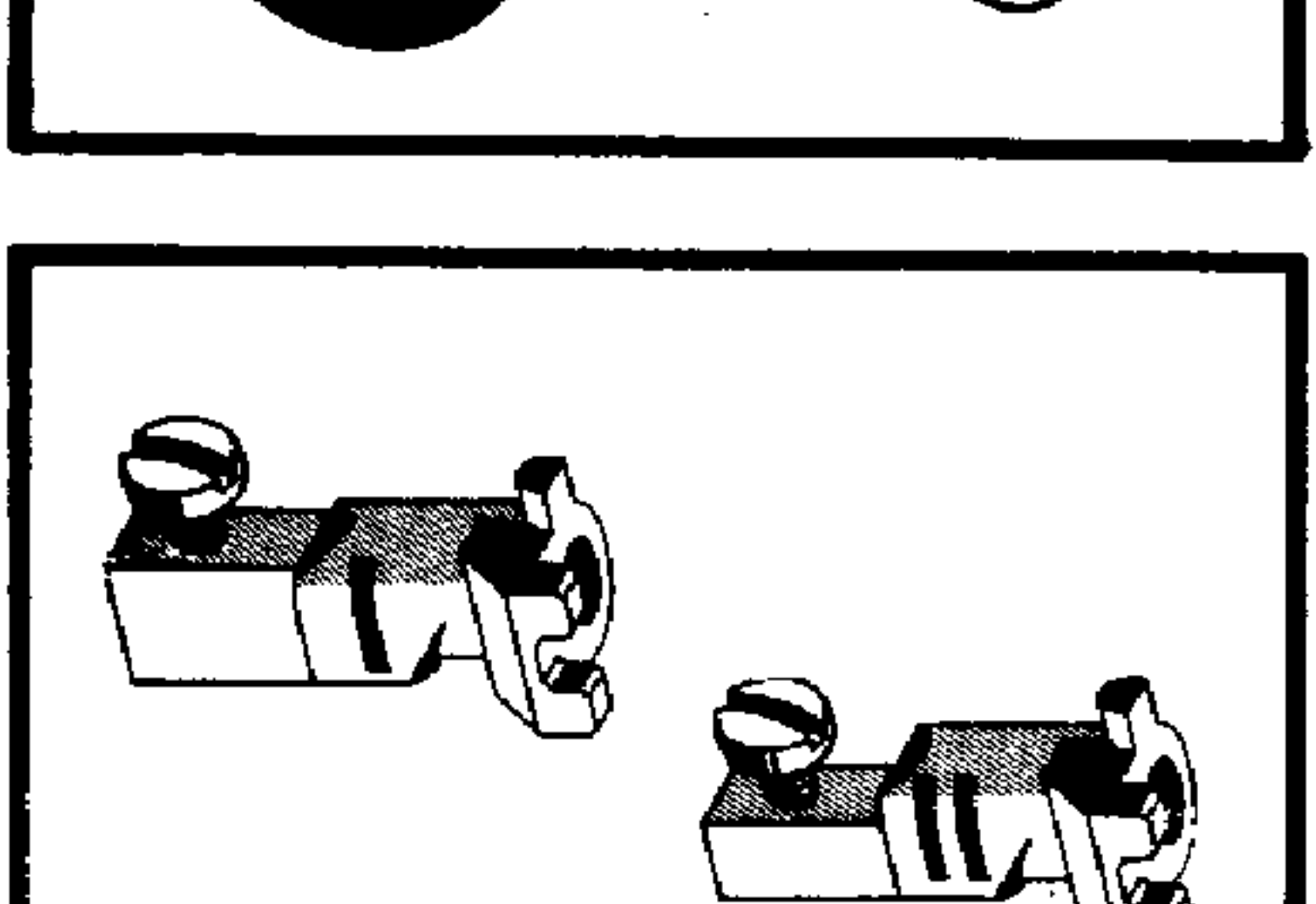

**FOOT ADAPTORS**  
For use with old style screw on feet or attachments.  
No. 530652 (short) for Free Arm Models.  
No. 530650 (long) for Flat Bed Models.

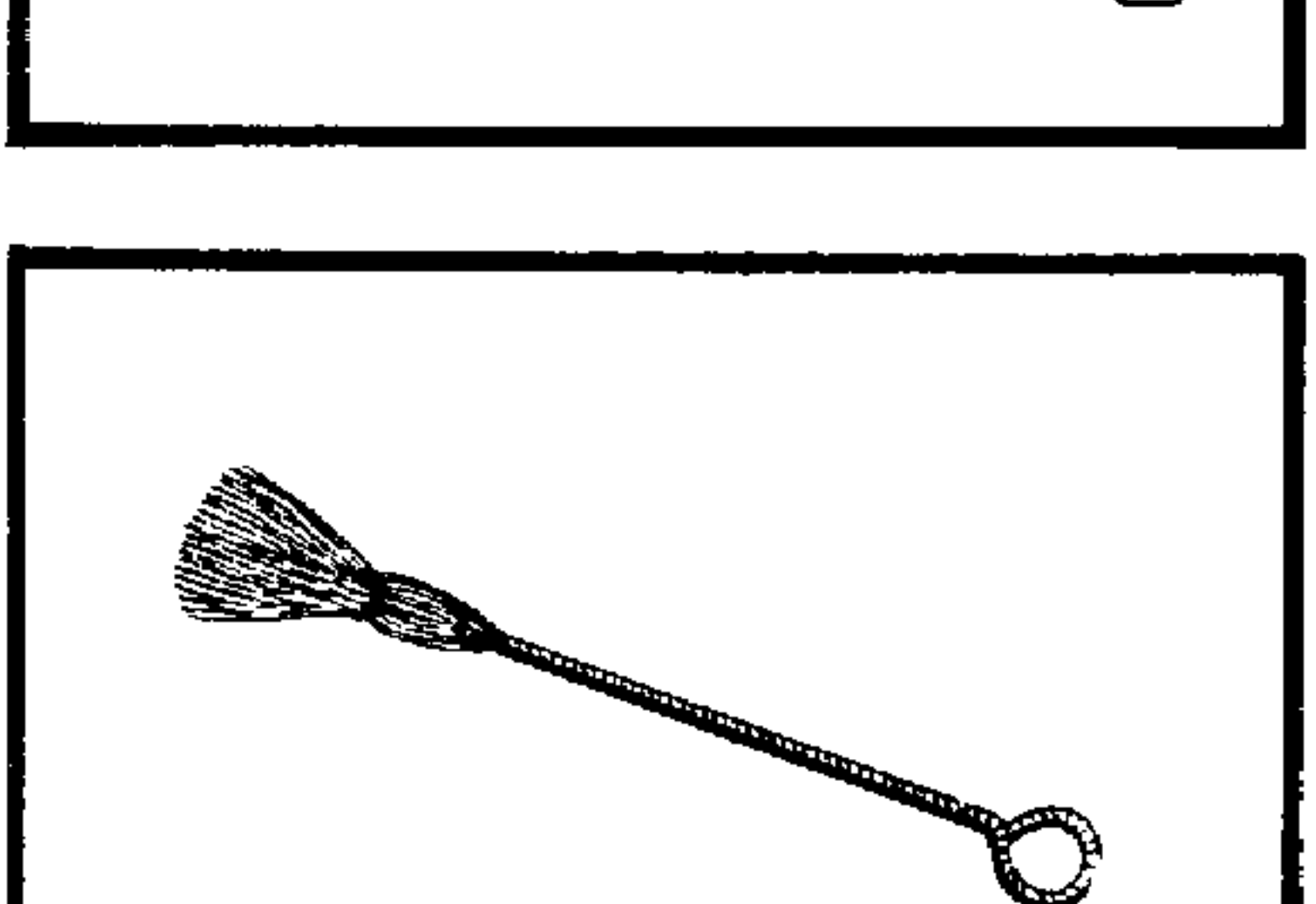

**CLEANING BRUSH**  
For cleaning away dust and fluff around feed and shuttle.  
No. 531128  
For all models.

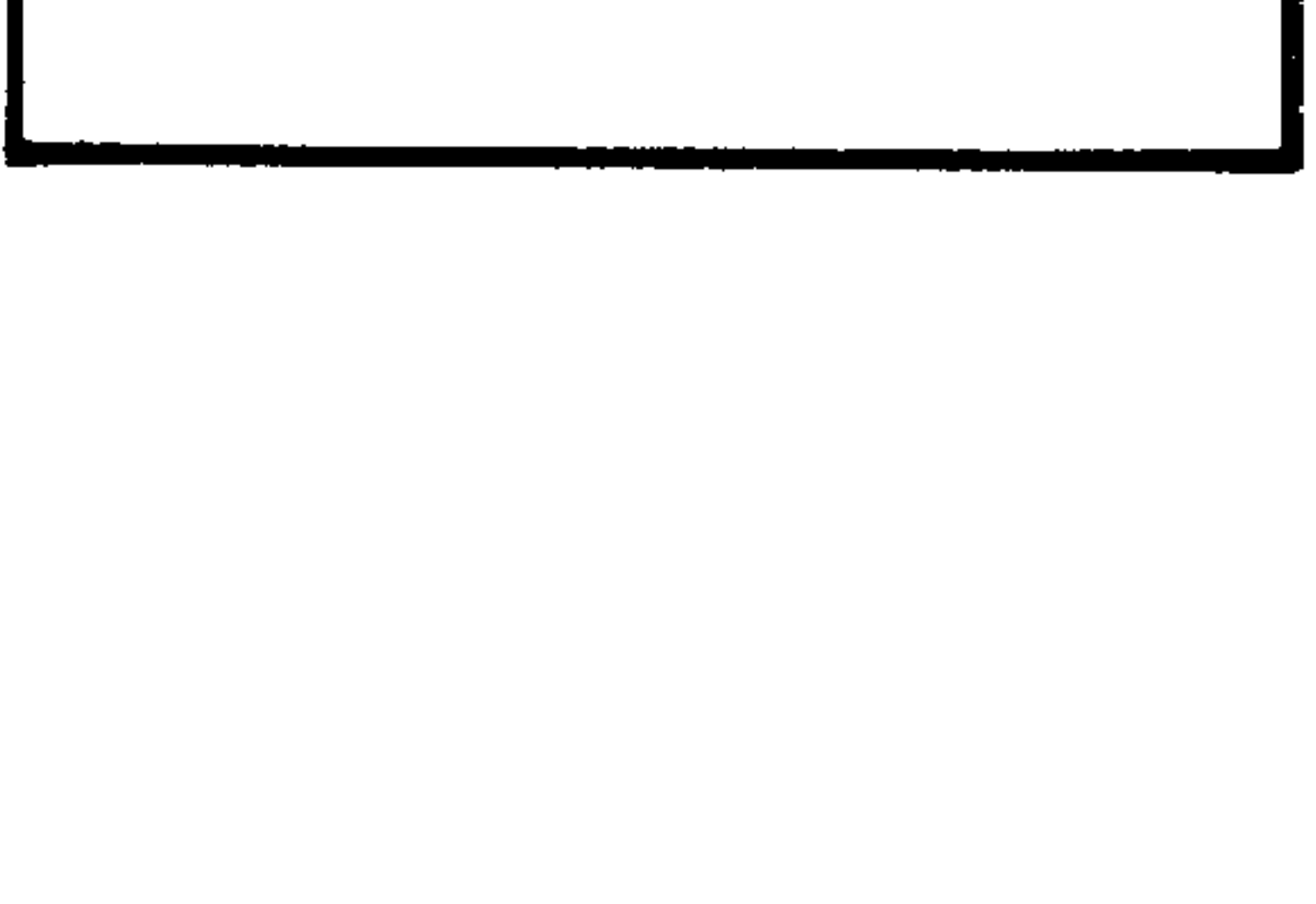

**SCREWDRIVER**  
No. 531131 large  
No. 531132 tensile  
No. 601133 special  
For all models.

*needle ?*